

Build your own Geiger-Müller counter

Introduction: Geiger Counters and Radiation Detection

For this project, you will be building a very basic Geiger-Müller (GM) counter. The GM counter is a fundamental type of radiation detector (one of the first, introduced in 1928), consisting of a gas-filled tube surrounding a high voltage wire. The electric field between the tube wall and the wire is such that ionizing radiation incident on the tube will cause the gas to break down and allow a pulse of current to flow between the wire and the wall of the tube. The geometry is shown in Figure 1.

The circuit for the GM counter you will be building is designed to be fairly simple: you will be equipped to understand it by the end of 22.071. You will learn more about radiation measurement in 22.09 and you will learn more about nuclear physics and radiation in 22.02.

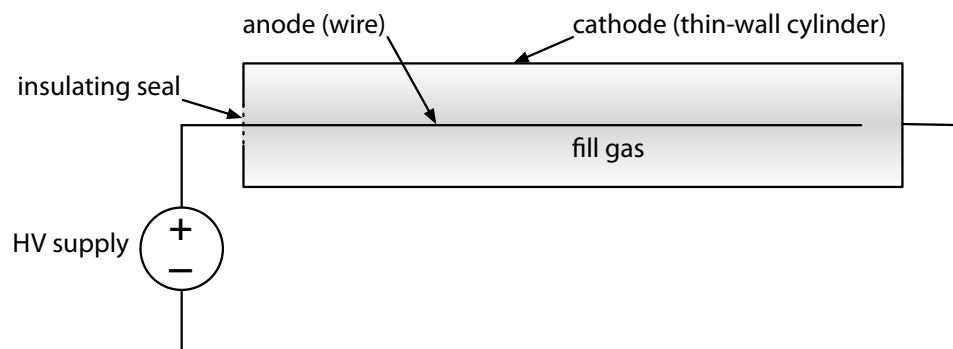

Figure 1: Basic geometry of a Geiger-Müller tube.

Background

Basics of Radiation

The term *radiation* can refer to any of the following:

- Electromagnetic radiation (visible light, X-rays, microwaves, γ rays)
- Fast electrons/positrons (β particles)
- Heavy charged particles (α particles, fission fragments)
- Free neutrons

In the context of nuclear engineering, we will primarily be concerned with radiation that results from any of a variety of nuclear reactions, including the spontaneous decay of a nucleus, the fission of a nucleus and the fusion of two nuclei. A nucleus undergoes radioactive decay in order to reach a more stable state – the excess energy (usually designated as Q) is carried away by the decay products. Radiation which has sufficient energy to produce ionization in common materials is said to be *ionizing* radiation. The lower threshold for this is about 10 eV, where $1 \text{ eV} = 1.6 \times 10^{-19} \text{ J}$ is a convenient unit for energy used in both nuclear engineering and physics. The *activity* of a sample is the number of decays per second and is often expressed in *curies*: $1 \text{ Ci} = 3.7 \times 10^{10} \text{ decays/s}$ (roughly the activity of 1 g of ^{226}Ra).

In *alpha decay*, the nucleus splits off an alpha particle consisting of two protons and two neutrons (i.e., a helium nucleus). Heavy charged particles such as alphas

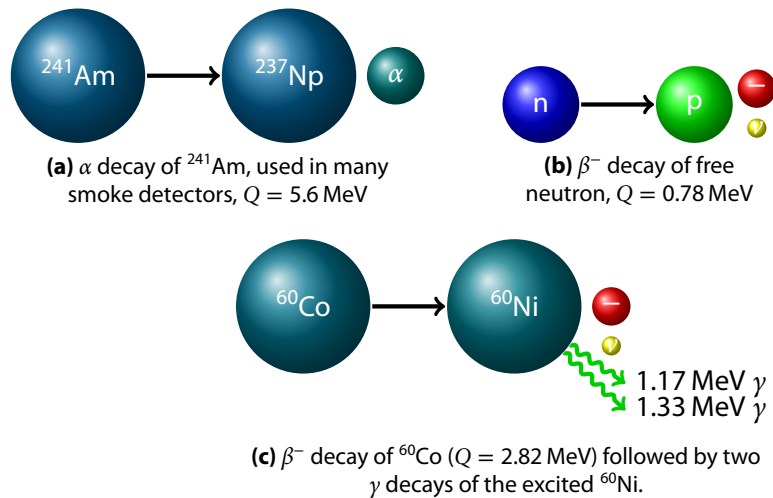

Figure 2: Illustrations of the various decay types.

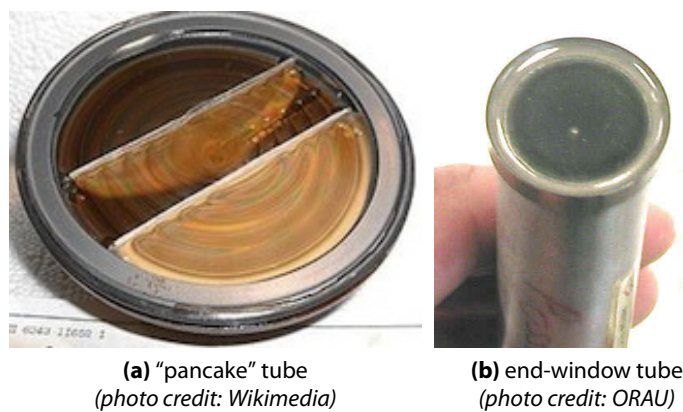

Figure 3: Examples of alpha-sensitive tubes: (a) is a "pancake" tube with a large-area mica window and an anode made of concentric rings. (b) shows the mica window of an end-window tube. The tip of the anode wire can be seen in the middle of the window.

interact with matter primarily through the electric forces between their positive charge and the negative electrons in the absorbing matter. As a high-energy alpha passes through matter, it slows down through many such interactions with the light electrons. Because any given interaction is very small, the particle trajectory tends to be mostly straight. The range of alpha particles is fairly short – in air, a 2 MeV alpha has a mean range of only about 1 cm! Hence, detectors for alpha radiation must have a very thin wall – often mica with a thickness of around 0.001" is used, see Figure 3 for examples. The SBM-20 tubes we will be using have steel walls that are too thick to be used for alpha radiation.

There are two forms of *beta decay*. In β^- decay, a neutron in the nucleus essentially splits into a proton, an electron and a neutrino, thereby increasing the atomic number of the decaying nucleus. In β^+ decay, a proton in the nucleus essentially splits into a neutron, a positron (anti-electron) and a neutrino, thereby decreasing the atomic number of the nucleus. Electrons also interact primarily with the electrons in the absorbing material. Because the masses are equal in this case, any given interaction can cause a large change in the trajectory – thus electron tracks meander more than those of alpha particles. Fast electrons also lose energy by emitting light in a process known as *bremsstrahlung*. Electrons typically have much longer ranges than alpha particles, and hence can be seen by the SBM-20 GM tubes we will be using.

Following a radioactive decay, a nucleus is often left in an excited state. When this state decays, a very high energy photon is emitted in what is called *gamma decay*. Photons can lose their energy through several mechanisms: photoelectric

absorption by the electrons of the absorber, Compton scattering from the electrons of the absorber and (at high energies) pair production in the electric field of the nuclei in the absorber. Gamma rays also have long ranges and hence can be detected by the SBM-20 GM tubes we will be using. You can tell the difference between beta and gamma radiation based on how easy it is to block with a high-Z absorber such as lead – gamma will penetrate the barrier more readily than beta.

Principles of Soldering

Safety Note: Solder contains lead – be sure to **wash your hands after handling solder**, and do not solder near food or drink!

Safety Note: Molten solder can be flung towards you if a component slips. **Always wear eye protection when soldering!**

Electronics are assembled using *solder*, alloys designed to have a low melting point, high electrical conductivity and good mechanical properties. The solder we will be using is 60% tin and 40% lead. The following tips will help you to make a secure joint every time:

- Before you apply solder to a joint, make sure the joint is mechanically stable. For example, when soldering to a circuit board, bend the leads outwards once they are through the hole.
- Clean the iron's tip on a moist sponge or brass sponge before and after making each joint.
- Put a small amount of solder on the tip of the iron right before touching it to the part – this will help to conduct heat to the part.
- Make sure the tip of the iron contacts *both* parts to be connected – you need them both hot to make a good joint!
- Feed the solder into the joint from opposite where the iron touches – if the solder doesn't melt, then you probably haven't gotten the joint hot enough.
- Don't overheat parts – a few seconds should do it. If you can't get the solder to melt as described above within about ten seconds or less, take the iron away, clean the tip and put more solder at the tip of the iron to help conduct heat better.
- A good solder joint should be shiny and “wetted” to the surface, *not* dull and “balled up” on the surface – see Figure 4.

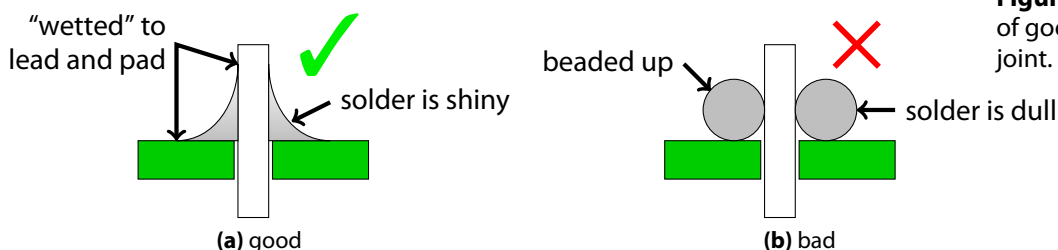

Figure 4: Cross-section of good versus bad solder joint.

Resistors

Resistors are one of the fundamental building blocks of electronics. As implied by the name, they resist the flow of current. Given a current I , a resistor of value R develops a potential difference $V = IR$ across it (Ohm's law). The value of a resistor is indicated by the color code shown in Figure 5.

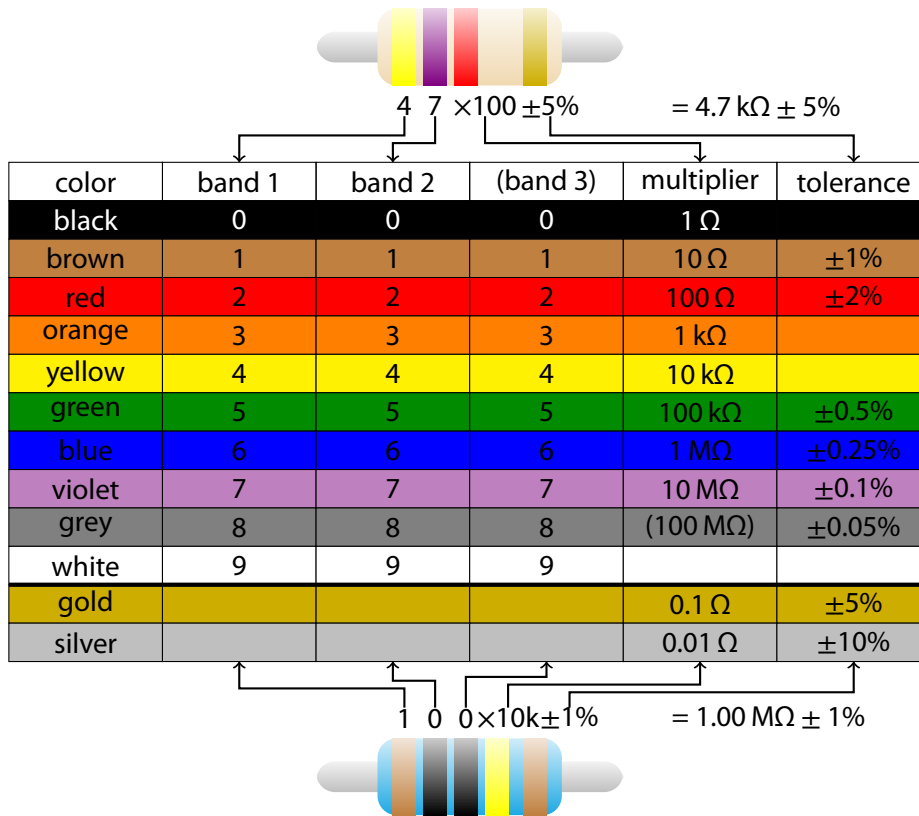

Figure 5: Resistor color code chart. The value of the resistor is indicated by two or three value bands, a multiplier band and a tolerance band. Note that 1% and 2% resistors are ambiguous as brown and red are valid as both tolerance and value bands – always double-check the value of precision resistors!

Capacitors

Capacitors are another fundamental building block of electronics. A capacitor stores charge: given a capacitor of capacitance C charged to a potential V , the charge stored is $Q = CV$. The value of the capacitors we will be using is indicated by a three-digit number code that works similarly to the resistor color code described above: the first two digits are the first two digits of the value and the third digit is the power of ten multiplier to get the capacitance in picofarads ($1 \text{ pF} = 10^{-12} \text{ F}$). For example, the code “224” means $22 \times 10^4 \text{ pF} = 220 \text{ nF}$.

Inductors

Inductors are the third fundamental building block of electronics. An inductor responds to *changes* in current: given an inductor of inductance L with time-varying current I flowing through it, the voltage is $V = LdI/dt$. The value of the inductor we will be using is indicated by a three-digit number code that works very much like the capacitor code described above: the first two digits are the first two digits of the value and the third digit is the power of ten multiplier to get the inductance in microhenries ($1 \mu\text{H} = 10^{-6} \text{ H}$). For example, the code “102” means $10 \times 10^2 \mu\text{H} = 1 \text{ mH}$.

Assembling the Geiger-Müller Counter

The circuit diagram is shown in Figure 6. The parts needed are shown in Figure 7 and parts lists broken down by subassembly are given at each step. You will be assembling the circuit on a printed circuit board (PCB), the top of which is shown in Figure 8. In the subsequent steps, components involved in the active step will be shown in full color and components that have already been installed but are unimportant for the step at hand will be shown as black silhouettes.

Tip: Always disconnect the battery when done testing – you don't want to wreck your circuit by shorting it out!

Tip: When testing, always make sure the board is supported such that there is nothing shorting any connections out on it – this includes your hands as well as any debris on your workbench. The two safest approaches are to grip the edges of the board with the work holder such that the board is held off the workbench or to put standoffs in the mounting holes at the corners of the board.

Tip: With components that start out with short leads that you can't bend to hold the part in place, it sometimes helps to use a small piece of tape to hold the part in place while soldering.

Safety Note: When using wire cutters, wire fragments can be flung with enough force to injure your eyes. **Keep your eye protection on while trimming leads.** Another useful tip is to hold your hand over the area where you are cutting to catch the leads as you trim them.

Troubleshooting Tips

If a circuit doesn't work as expected, check the following:

1. Make sure the correct components have been placed in the correct spots.
2. Check the orientation of diodes, transistors and chips with respect to the silkscreen outline.
3. Make sure that adjacent pads didn't become shorted together ("bridged") during soldering.
4. Make sure you are making the measurement properly: always hook the ground of your scope and the "COM" lead of your meter to the "GND" pin or one of the grounded mounting holes in the corners of the board.

Figure 6: Full schematic for the GM counter.

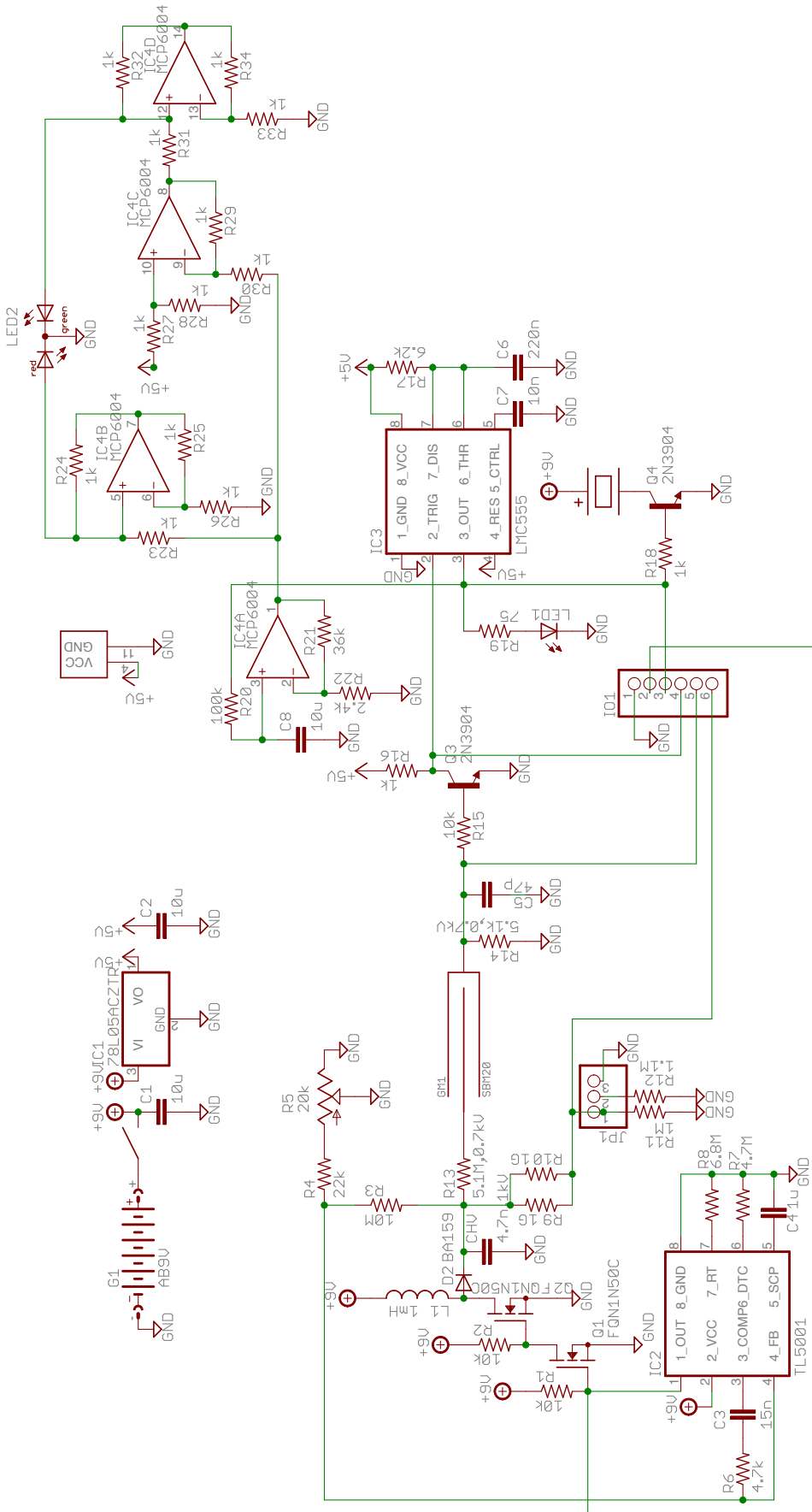

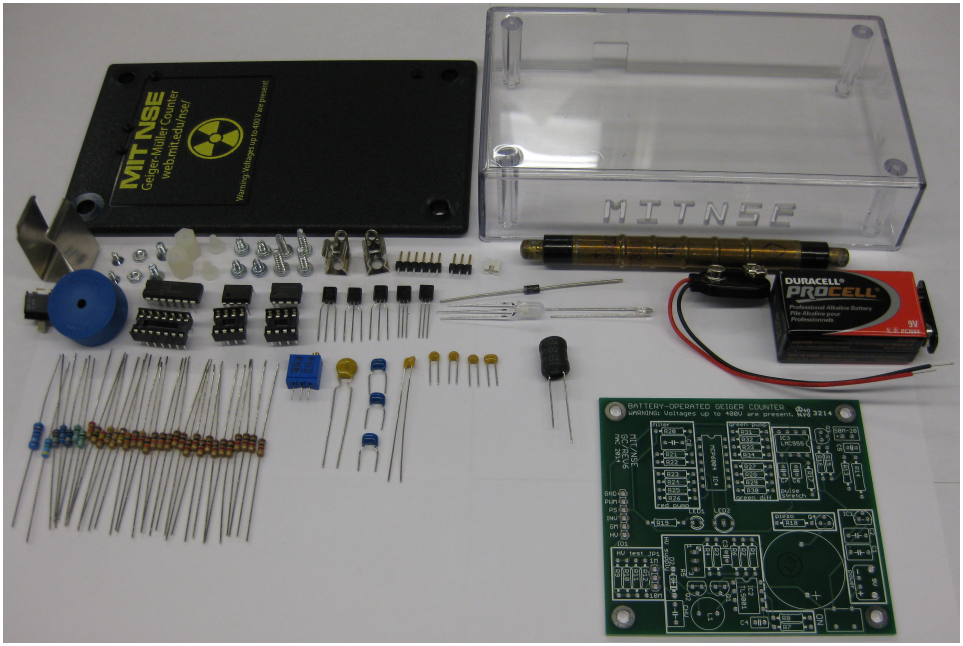

Figure 7: Parts of the GM counter.

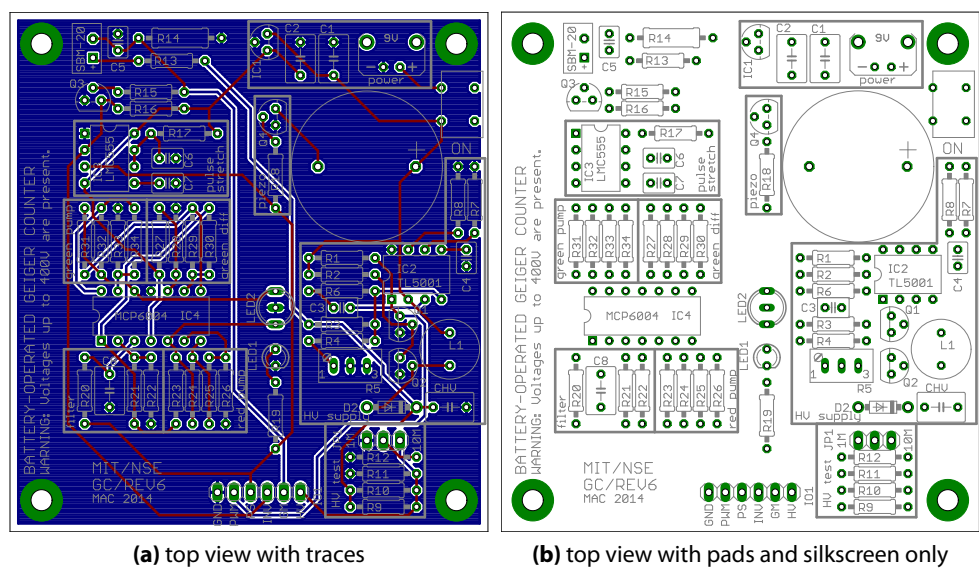

Figure 8: The board has two layers – in (a) the top layer is shown as red and the bottom layer is shown as blue. Notice that most of the bottom layer is a solid area of copper – this is the *ground plane*, and is what is defined as zero volts for the circuit.

(a) top view with traces

(b) top view with pads and silkscreen only



Step 1: Build the power supply

Note: The 78L05 linear regulator must be installed in the correct orientation in this step. Be sure you have it right before soldering it in!

Note: Don't get the 78L05 linear regulator mixed up with the transistors, which are in the same style of package!

The power supply provides the 5 V that the rest of the circuit runs on.

Parts Used

Name	Description/Value	Diagram
9V	battery snap	-
-	slider switch	
IC1	78L05	
C1, C2	10 μ F filtering capacitor	 (x2)

flat side faces to right

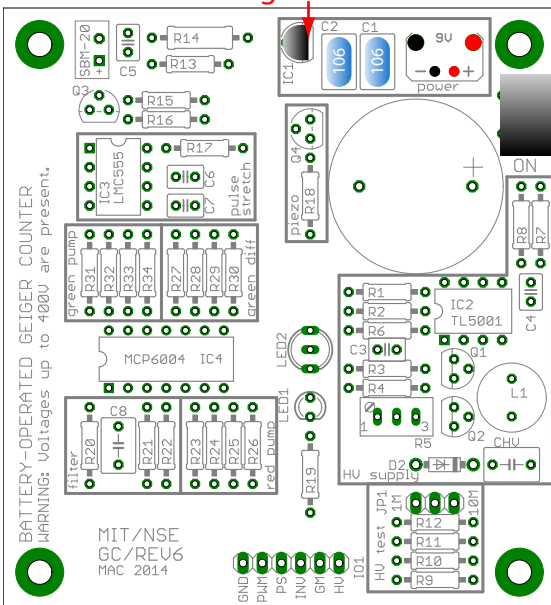

1. Hook up the leads from the battery snap as shown in Figure 9, taking care that the red wire goes on the side marked with a “+.” Be sure to follow Figure 9 closely or the wires to the battery will soon break!
2. Solder the battery wires from the top of the board, trim any excess length.
3. Insert the parts as shown in the diagram. **Make sure the flat side of the 78L05 linear regulator faces towards the two large capacitors.**
4. Flip the board over, grip the edges with the work holder (if using one).
5. Solder all of the wires you just inserted and trim the excess lead length protruding from the board.

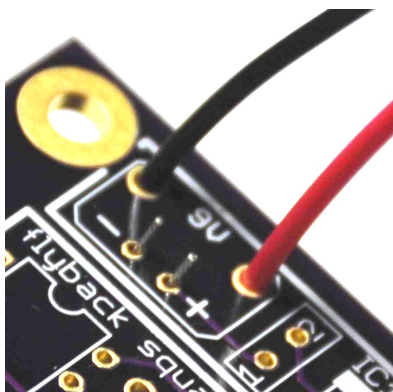

(a) top of board

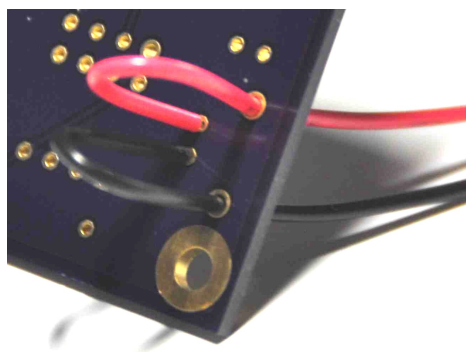

(b) bottom of board

Figure 9: Thread the battery leads in from the top of the board and up again through the back, leaving a loop to take up strain.

Step 2: Test the power supply

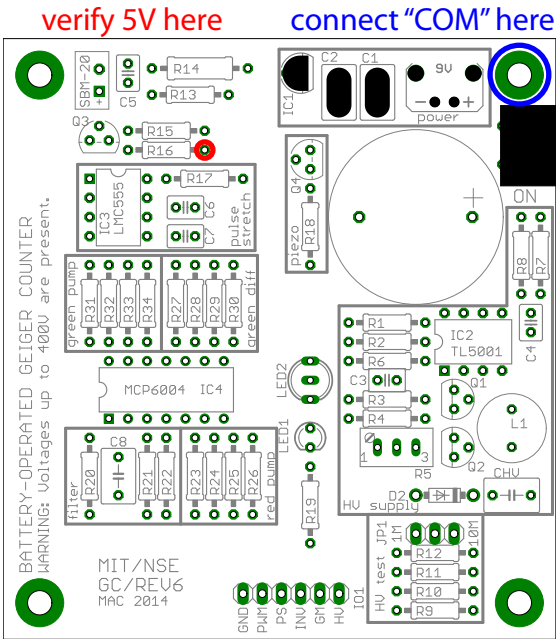

1. Support the board such that none of the connections are shorted by hands, lead clippings, etc.
2. Check that the power switch is in the “off” position (i.e., away from the text “ON” printed on the board).
3. Connect the battery and turn on the power switch.
4. Using the digital multimeter (DMM), check that the voltage at the pad indicated with the red circle in the figure is at about 5 V with respect to any of the grounded mounting holes in the corners.
5. Turn the power switch off.
6. Disconnect the battery.

Step 3: Build the inverter

Note: There are two parts that must be installed in the correct orientation in this step. Be sure you have them right before soldering them in!

The inverter inverts the pulse from the GM tube.

flat side faces towards bottom

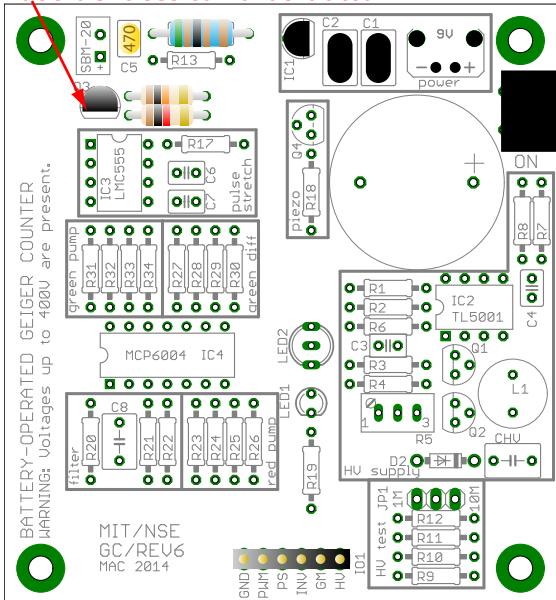

Parts Used

Name	Description/Value	Diagram
R14	5.1 kΩ 1/2 W resistor	
R15	10 kΩ resistor	
R16	1 kΩ resistor	
C5	47 pF capacitor	
Q3	2N3904 NPN transistor	
IO1	6-pin header	

1. Insert the parts as shown. **Make sure the FLAT side of the transistor faces DOWN.**
2. The **short** end of the 6-pin header goes into the board, **with the plastic part on top**, see Figure 10.
3. Flip the board over, solder all of the components in and trim the excess leads.

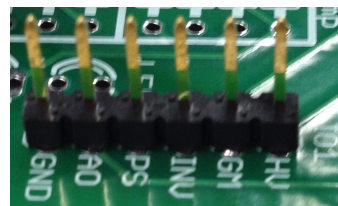

Figure 10: Correct header installation: long gold pins and plastic on TOP of board.

6-pin output header description

The 6-pin header you just installed provides easy access to the important signals in the circuit, summarized in the table below:

IO header pin descriptions

Label	Description
HV	1000:1 voltage divider on HV power supply
GM	GM tube I-to-V output
INV	Inverter output
PS	Pulse stretcher output
PWM	Power converter switching waveform
GND	Ground

Note: Whenever you are using the oscilloscope, always connect the shield (black lead when using a BNC-to-minigrabber cable) of each channel to the “GND” pin. Be careful to not short to adjacent pins!

Step 4: Test the inverter

use a wire to connect the nodes circled in red

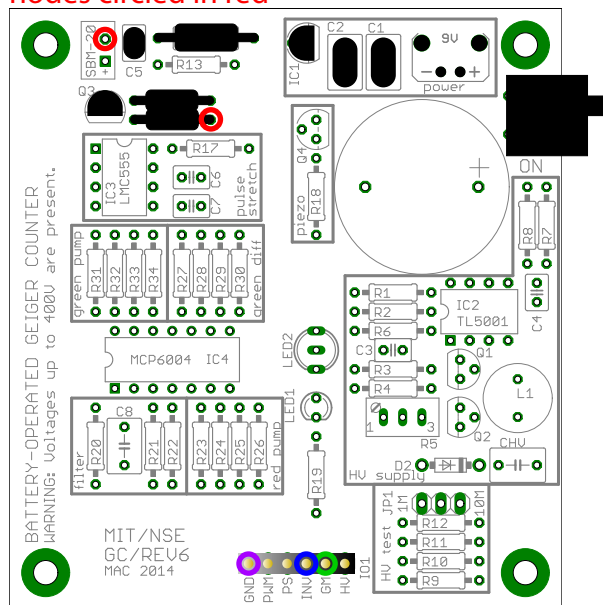

hook A to “GM”
hook B to “INV”
ground both channels to “GND”

1. Connect channel A of the scope to “GM.”
2. Connect channel B of the scope to “INV.”
3. Don’t forget the ground connections to “GND” for both channels!
4. Check that the power switch is off and that the board is supported away from any materials that might short it out.
5. Connect the battery, turn the power switch on.
6. Use a wire to short the two pads circled in red together, being careful to not touch adjacent pads.
7. On the scope, observe the signal from your wire on channel A and the output from the inverter on channel B, you should see signals like Figure 11.
8. Turn the power switch off and disconnect the battery.

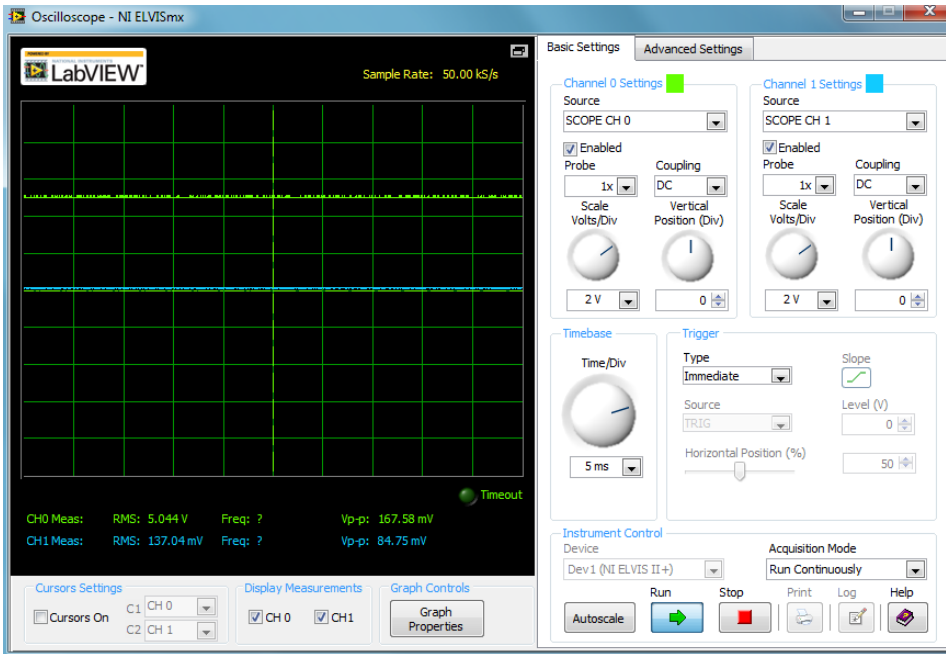

Figure 11: Waveforms for the inverter test. The simulated GM pulse is channel A (green), the inverter output is channel B (blue). The inverter takes the 5 V pulse signal and converts it to zero. With the wire removed, the traces will be reversed – the inverter will output 5 V on channel B while the pulse on channel A is zero.

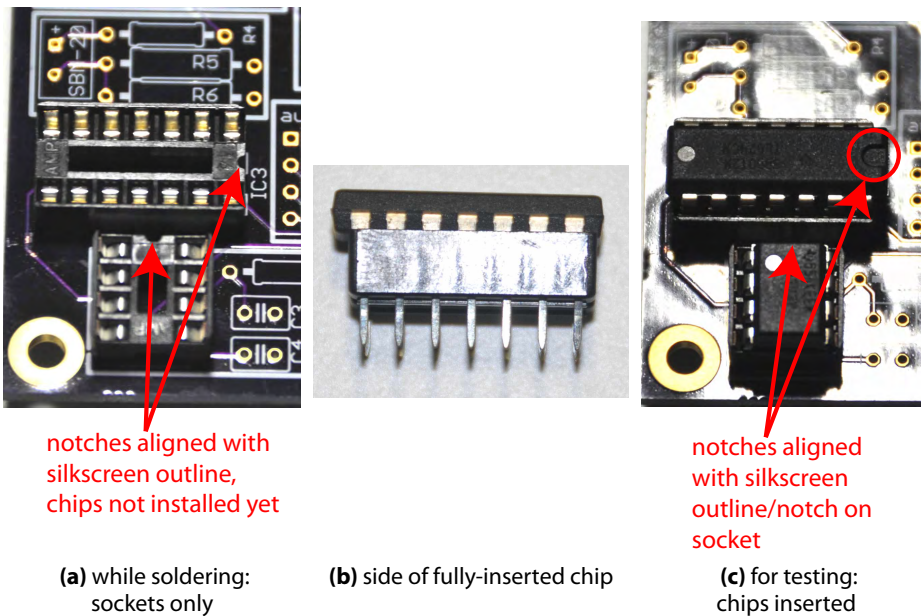

Figure 12: Chip sockets allow chips to be removed without needing to remove any solder. When installing a chip, it is very important to **make sure the notch on the top of the chip is in the right spot** and that the chip is fully seated in the socket.







(Note that what is shown is a slightly different board than what you are building.)

Step 5: Build the pulse stretcher

Note: There are two components that must be installed in the correct orientation in this step. Be sure you have them right before soldering them in!

The pulse stretcher turns the very short pulse from the GM tube into a 1.5 ms pulse.

Parts Used

Name	Description/Value	Diagram
IC3	LMC555 timer (and DIP-8 socket)	
R17	6.2 kΩ resistor	
R19	75 Ω resistor	
C6	220 nF capacitor	
C7	10 nF capacitor	
LED1	small blue LED	

1. We will be using chip sockets to make it easier to replace chips if something goes wrong: see Figure 12. **Do not insert the chips themselves until the last step.**
2. Insert the small LED **with the longer lead in the hole nearest to where LED2 will go.**
3. Insert the parts as shown in the diagram, bending leads as necessary to hold them in place. **Make sure to line up the notch at the top of the chip socket with the notch indicated on the silkscreen outline.**
4. Flip the board over, solder all of the components in and trim the excess leads.
5. Insert the 555 chip into its socket **with the notch as shown on the silkscreen outline.**

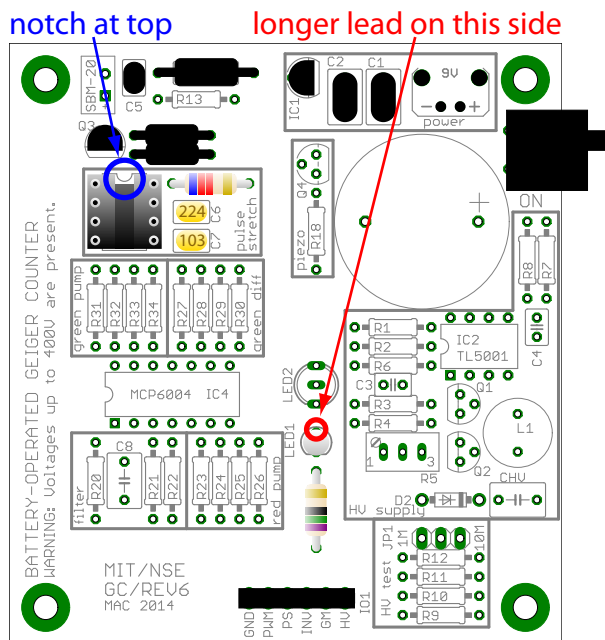

Step 6: Test the pulse stretcher

use a wire to connect the nodes circled in red

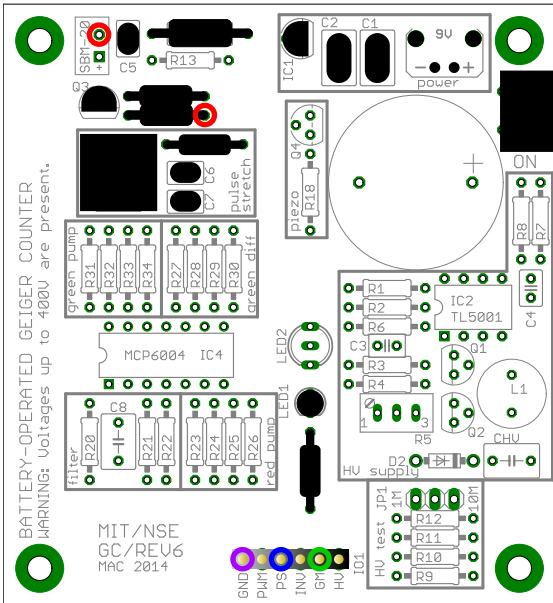

hook A to "GM"
hook B to "PS"
ground both channels to "GND"

1. Connect channel A of the scope to "GM."
2. Connect channel B of the scope to "PS."
3. Don't forget the ground connections to "GND" for both channels!
4. Check that the power is off and that the board is away from any materials that might short it out.
5. Connect the battery, turn the power switch on.
6. Use a wire to short the two pads circled in red together, being careful to not touch adjacent pads.
7. On the scope, observe the signal from your wire on channel A and the pulse stretcher on channel B.
 - If you could tap the wire briefly enough, the pulse stretcher should put out a 1.5 ms long square pulse – tapping this fast is hard to do!
 - Otherwise, the stretcher will be on as long as the wire is in contact.
 - When the pulse stretcher is on, the blue LED should light up.
 - You should see signals like Figure 13.
8. Turn the power switch off and disconnect the battery.

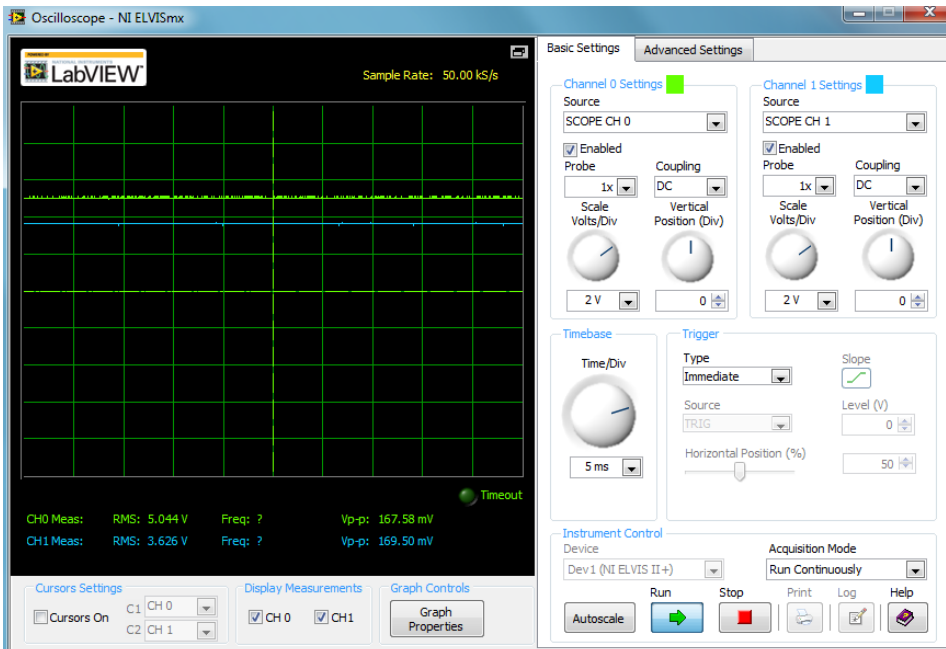
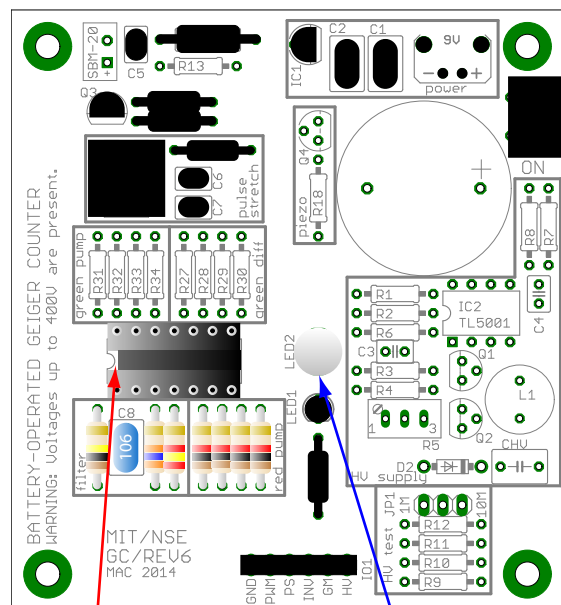

Figure 13: Waveforms for the pulse stretcher test. The simulated GM pulse is channel A (green), the pulse stretcher is channel B (blue). Channel B can be up to 5 V, in which case the two traces would be right on top of each other.

Step 7: Build the filter and red LED pump

Note: The chip and LED must be installed in the correct orientation in this step. Be sure you have them right before soldering them in!

The filter collects the GM tube pulses to control the color of LED2: the higher the count rate, the more red LED2 will get. The red pump drives this proportional current through the red LED.



notch to left

flat side to bottom

Parts Used

Name	Description/Value	Diagram
IC4	MCP6004 quad op-amp (and DIP-14 socket)	
LED2	large red-green LED	
R20	100 kΩ resistor	
R21	36 kΩ resistor	
R22	2.4 kΩ resistor	
R23, R24, R25, R26	1 kΩ resistor	(×4)
C8	10 μF capacitor	

1. Set the MCP6004 chip aside until the last step.
2. Insert the other parts into the board as shown.
3. **Make sure the notch at the top of the chip socket is oriented as indicated on the silkscreen outline.**
4. **The FLAT side of the large LED should face towards LED1.** (The flat is only present on the thin band at the base of the plastic housing.)
5. Flip the board over, solder all of the components in and trim the excess leads.
6. Insert the MCP6004 chip into its socket **with its notch towards the edge of the board.**

Step 8: Test the red LED pump

1. Check that the power switch is off and that the board is supported away from any materials that might short it out.
2. Connect the battery, turn the power switch on.
3. Repeat the procedure from the previous tests: hold a wire at the right lead of R16 and tap it on the lower, circular pad of the SBM-20.
4. You should see the red LED light up as you hold the wire in place, then gradually fade away when you remove the wire.
5. Turn the power switch off and disconnect the battery.

Step 9: Build the green LED difference amplifier and pump

The green difference amplifier and pump drive current through the green LED inversely proportional to the count rate.

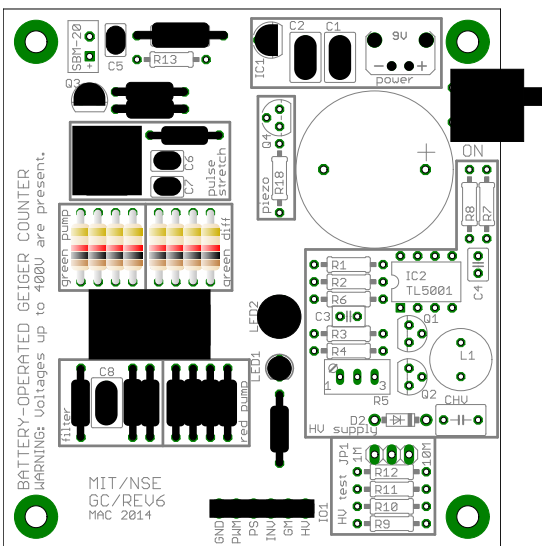

Parts Used

Name	Description/Value	Diagram
R27, R28, R29, R30, R31, R32, R33, R34	1 kΩ resistor	 (x8)

1. Insert the parts into the board as shown.
2. Flip the board over, solder all of the components in and trim the excess leads.

Step 10: Test the green pump

1. Check that the power switch is off and that the board is supported away from any materials that might short it out.
2. Connect the battery, turn the power switch on.
3. Repeat the procedure from the previous tests: hold a wire at the right lead of R16 and tap it on the lower, circular pad of the SBM-20.
4. The LED should go from green to red as you hold the wire in place, then fade back to green when you remove the wire.
5. Turn the power switch off and disconnect the battery.

Step 11: Build the piezo driver

Note: The transistor and piezo must be installed in the correct orientation in this step. Be sure you have them right before soldering them in!

The piezo driver uses the full battery voltage to produce more volume from the high-impedance piezoelectric speaker.

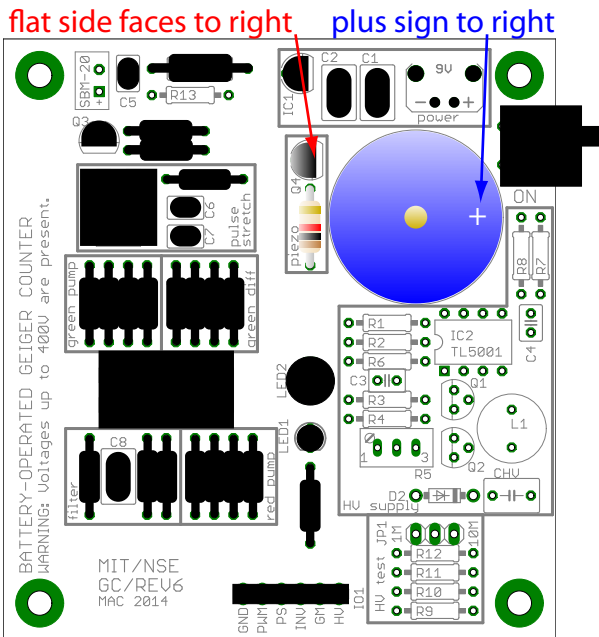

Parts Used

Name	Description/Value	Diagram
-	piezo speaker	
R18	1 kΩ resistor	
Q4	2N3904 NPN transistor	

1. Insert the components as shown, *making sure to put the transistor in with the flat side facing TOWARDS the piezo as indicated on the silkscreen outline.*
2. *Also make sure the plus sign on the piezo is in the hole closest to the edge of the board.*
3. Flip the board over, solder all of the components in and trim the leads.

Step 12: Test the speaker

1. Check that the power switch is off and that the board is supported away from any materials that might short it out.
2. Connect the battery, turn the power switch on.
3. Repeat the procedure from the previous two tests: hold a wire at the right lead of R16 and tap it on the lower, circular pad of the SBM-20.
4. If you tap briefly enough you should hear a sharp click sound. The slower you are, the more of a tone you will hear. If you hold the wire in place, the tone will be continuous.
5. Turn the power switch off and disconnect the battery.



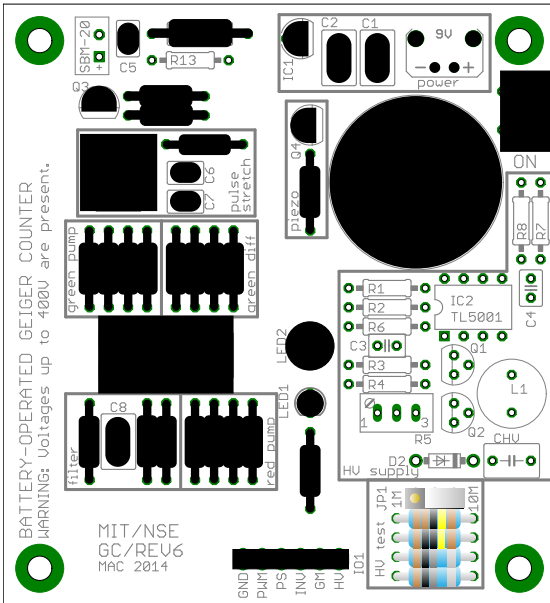

Step 13: Build the HV divider/bleeder

Note: The 3-pin header must be installed in the correct orientation in this step. Be sure you have it right before soldering it in!

The resistors installed in this step serve both to help drain the high voltage power supply's capacitor after the device is turned off and to form a 1000:1 voltage divider that helps you to safely measure the output of the power supply with conventional test equipment. Because of the high impedances involved, it is necessary to use different resistors for different input impedances of test equipment. The two possible states of jumper JP1 select the type of equipment used: 10 M Ω for a DMM, 1 M Ω for a standard oscilloscope.



Parts Used

Name	Description/Value	Diagram
R9, R10	1 G Ω resistor	 (×2)
R11	1 M Ω resistor	
R12	1.1 M Ω resistor	
JP1	3-pin header	
	2-pin jumper	

1. Set the 2-pin jumper aside until the last step.
2. The **short** end of the 3-pin header goes **into** the board, **with the plastic part on top**, just like the 6-pin header.
3. Insert the other parts as shown.
4. Flip the board over and grip it with the work holder, solder all of the components in and trim the excess leads.
5. Install the 2-pin jumper in the “10M” position.

Step 14: Build the boost converter

Safety Note: From this step on, **there will be parts of the board at 400 V** when turned on. The available current is small, but is still enough to give you a nasty shock (and probably destroy all of your chips in the process). **Be very careful to not touch the board whenever the battery is connected!**

Note: There are five components that must be installed in the correct orientation in this step. Be sure you have them right before soldering them in!

The boost converter steps the 9 V battery voltage up to the 400 V needed for the GM tube. The TL5001 is a general-purpose power converter controller that provides active control of the output voltage.

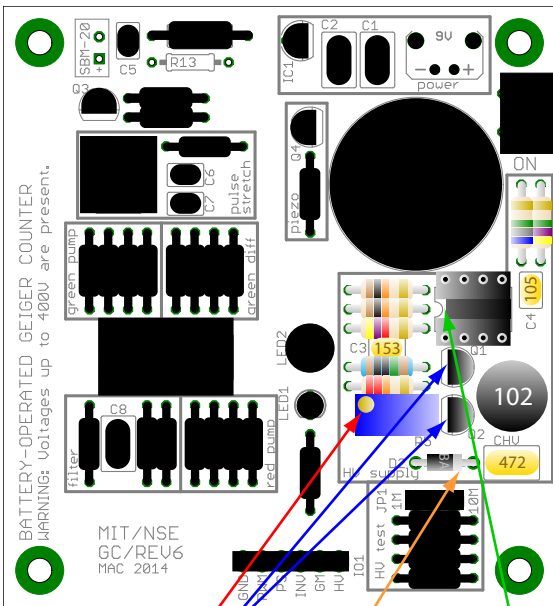

brass dot to left
flat sides to left
notch to left
silver band to right

Parts Used

Name	Description/Value	Diagram
IC2	TL5001 chip (and DIP-8 socket)	
D2	BA159 diode	
R1, R2	10 kΩ resistor	
R3	10 MΩ resistor	
R4	22 kΩ resistor	
R5	20 kΩ potentiometer	
R6	4.7 kΩ resistor	
R7	4.7 MΩ resistor	
R8	6.8 MΩ resistor	
C3	15 nF capacitor	
C4	1 μF capacitor	
CHV	4.7 nF HV capacitor	
Q1, Q2	FQN1N50C MOSFET	
L1	1 mH inductor	

1. Set the TL5001 chip aside until the last step.
2. Insert the other parts into the board as shown.
3. **Make sure the silver band on the diode is towards the HV capacitor as indicated on the silkscreen outline/in the diagram.**
4. **Make sure the notch at the top of the chip socket is oriented as indicated on the silkscreen outline.**
5. **Make sure the brass screw on top of the potentiometer ends up away from the transistors as shown on the silkscreen outline/in the diagram.**
6. **Make sure the flat sides of the transistors face AWAY from the inductor.**
7. Flip the board over, solder all of the components in and trim the excess leads.
8. Insert the TL5001 chip into its socket **with the notch to the left.**

Step 15: Note locations of high voltage

Safety Note: High voltage (up to 400 V) will now be present in the indicated regions. When testing, **be very careful to not touch the board!**

The shaded regions will be at 400V when the power switch is on!

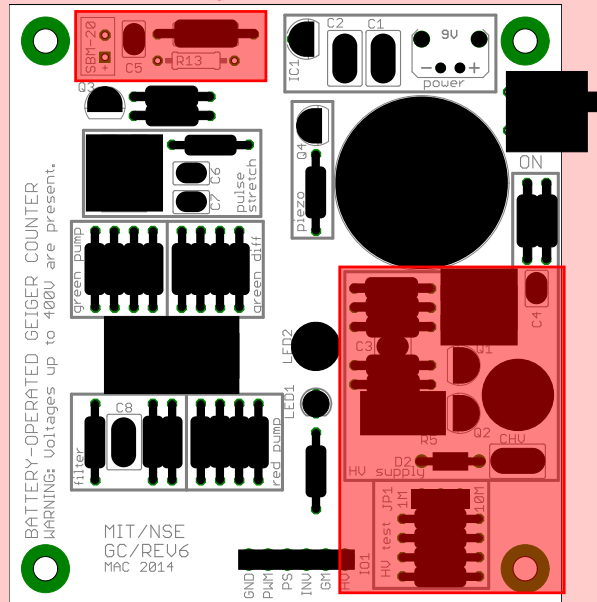

Step 16: Tune the boost converter

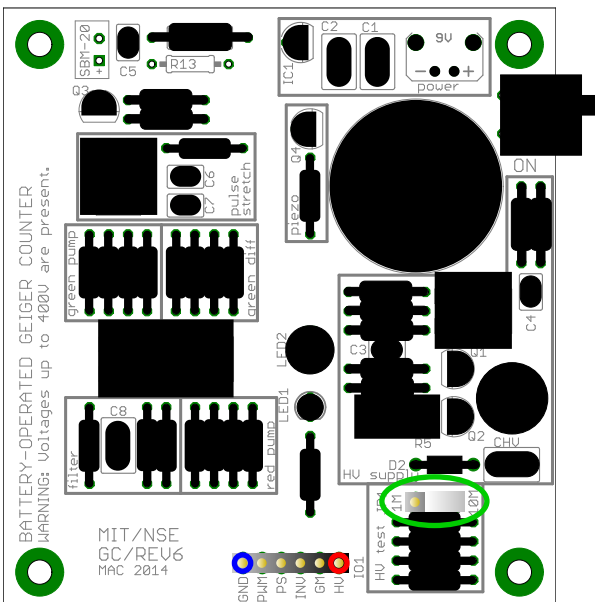

make sure jumper is at "10M"
measure HV supply on "HV"
be sure to connect meter "COM" to "GND"

1. Check that the power switch is off and that the board is supported away from any materials that might short it out.
2. Connect your DMM to the "HV" pin. Connect the DMM's "COM" lead to the "GND" pin.
3. Make sure that the jumper is set at "10M."
4. **Make sure no one is touching the board and that there are no debris that could create a short in contact with the board.**
5. Connect the battery, turn the power switch on.
6. Using the plastic adjusting tool, turn the brass potentiometer knob clockwise until the meter reads less than 300 mV. **Be careful to not touch the high voltage portions of the board while doing this!**
7. Then, turn the knob counterclockwise until the meter reads 400 mV. The divider is 1000:1, so this corresponds to 400 V output from the HV supply.
8. Turn the power switch off and disconnect the battery.

Step 17: Install the GM tube resistor and clips

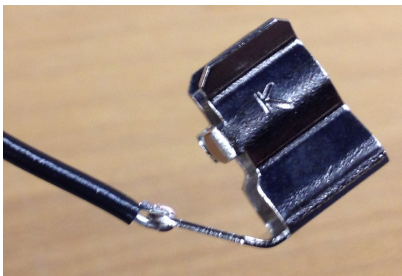
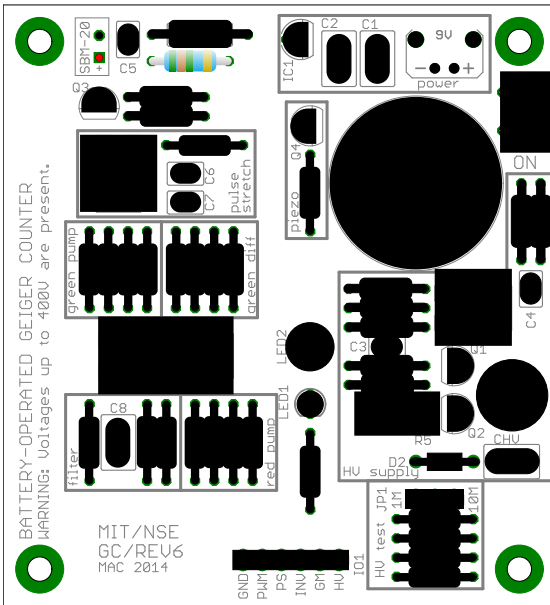

Figure 14: Wire ready to be soldered to clip.

Parts Used

Name	Description/Value	Diagram
–	fuse clips for GM tube	(×2)
R13	5.1 MΩ	

- Solder wires to the fuse clips:
 - Cut sections of red and black wire each about 6” (15 cm) long and strip about 1/8” (3 mm) of insulation from each end of these wires.
 - Use pliers to form one end of each wire into a “J” shape.
 - Hook the “J” into the hole in the tab on the clip, then crush the hook so it will stay still when soldering. Refer to Figure 14.
 - Solder the wires to the solder tab.
- At this point, you may wish to use the GM tube and case as a guide to trim your wires to a more appropriate length – but don’t cut too much off!
- Insert the loose end of the red wire into the hole marked with a “+,” insert the black wire into the other hole in the block labelled “SBM-20.”
- Insert the 5.1 MΩ resistor as shown.
- Flip the board over, solder all of the components in and trim the excess leads.

Step 18: Install into the case

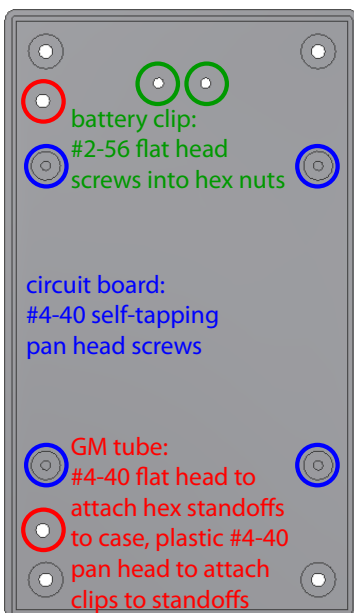

- Make sure the battery is disconnected, the power switch is off and that you have removed all debris from the board.
- Use #2-56 × 3/16” screws with nuts inside the case to secure the battery clip, then put a piece of electrical tape over the nuts to protect the battery.
- Use #4-40 × 3/16” self-threading screws to attach the board to the standoffs with the board oriented so the battery snap is close to the clip you just installed.
- Use #4-40 × 1/4” screws to attach the two hexagonal standoffs inside the case.
- Screw the fuse clips to the standoffs using plastic #4-40 × 3/16” screws. You might need to bend the clip out a bit using pliers, just don’t bend it too far!
- Bend the tabs on the fuse clips so they are nearly vertical.
- Insert the GM tube into the clips with the end marked with “+” at the clip with the red wire. **Be gentle when pushing down on the tube – it is very fragile!** Push down on the plastic right next to the clips to avoid crushing the tube.

Step 19: Test the GM tube

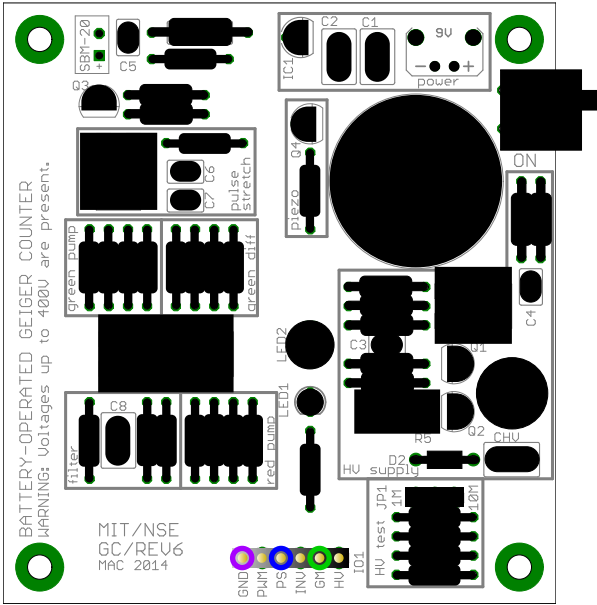

hook A to "GM"
hook B to "PS"
ground both channels to "GND"

1. Make sure the power switch is off and that no debris has fallen on the board.
2. Hook channel A of your scope to the "GM" pin.
3. Hook channel B of your scope to the "PS" pin.
4. Connect the battery, turn the power switch on.
5. At typical background levels, you should hear a click in the first 30 seconds or less.
6. Observe the signals on the scope and compare to Figure 15.
7. Turn the power switch off. You are now ready for final assembly.

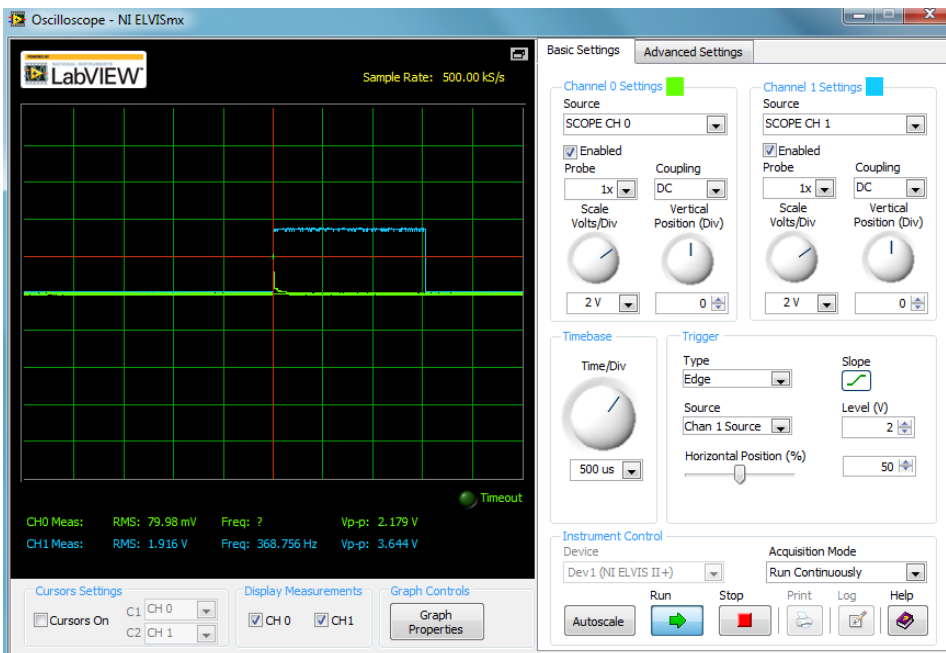

Figure 15: Waveforms for the complete GM counter. Channel A (green) is the actual pulse from the GM tube, channel B (blue) is the pulse stretcher. You can adjust the "Time/Div" knob to get a closer look at the pulse from the GM tube.

Step 20: Final assembly

1. Make sure the power switch is off.
2. Insert the battery into the clip and connect it.
3. ***Make sure the battery is not touching the clip holding the GM tube!***
4. If the posts in the top run into the tabs on the clips holding the GM tube, ***remove the GM tube to avoid damaging it***, then bend the tabs to be closer to vertical. Once the top fits, carefully put the tube back in, following the same precautions as before.
5. Put the top on with the rectangular notch over the power switch and secure it with the four self-threading screws.

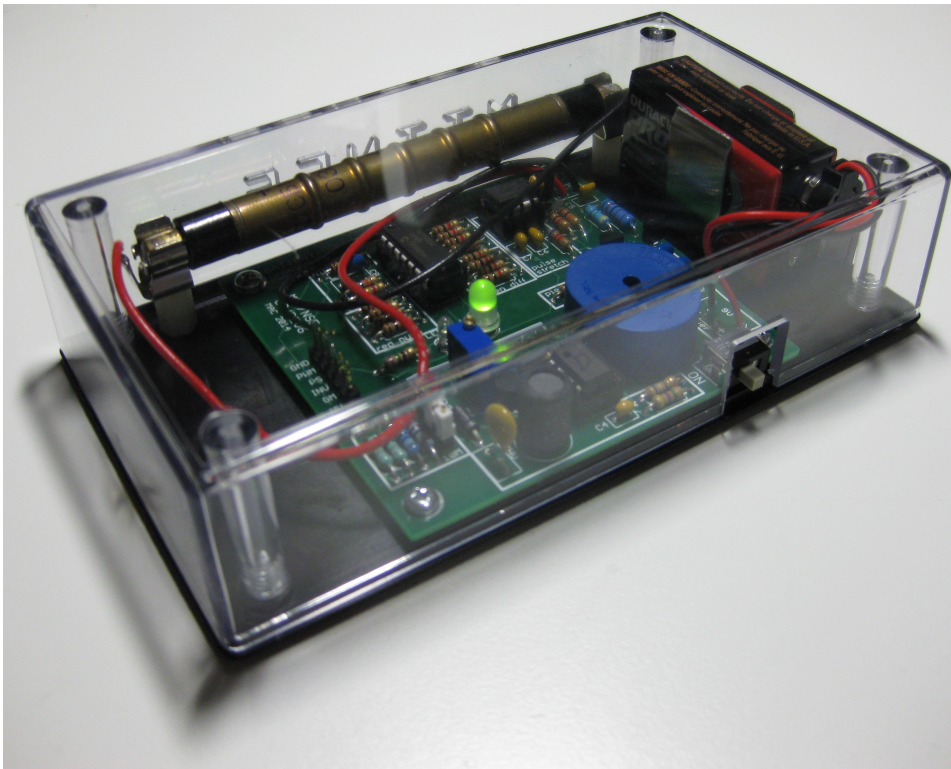

Figure 16: Completed GM counter.

This project was designed by Mark Chilenski (graduate student, Course 22). Numerous productive conversations were had with Prof. Anne White, Prof. Mike Short, Matthew D'Asaro (graduate student, Course 6) and John Walk (graduate student, Course 22) in the design of this project.